

Distributed by
British Cycle Supply
TRIUMPH OIL FILTER KIT

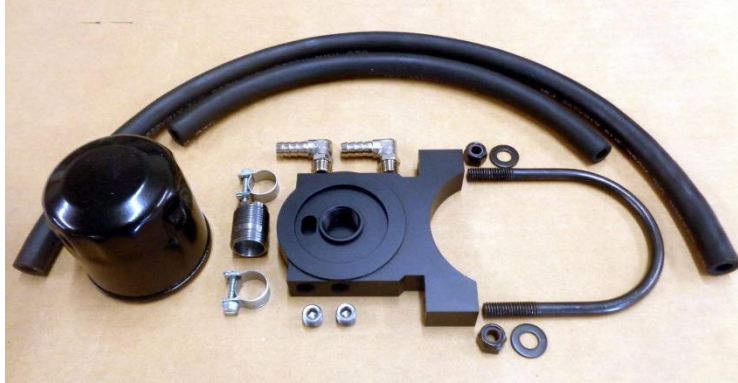

INSTALLATION INSTRUCTIONS

This Remote Oil Filter Kit is designed for Triumph 650cc and 750cc Oil in frame Motorcycles 1971-1988 and intended for installation in the oil return side of the oiling system.

(But you can install it on whatever you want)

Kit Contents: 1ea Oil filter mount body.
 1ea Oil filter attachment tube
 1ea Spin-on oil filter
 1ea Clamping U-bolt
 2ea U-bolt lock nut
 2ea U-bolt washer
 2ea Oil hose fitting, 90° swivel
 2ea Threaded plug
 2ea Hose Clamp
 2ea Oil hose

- 1- Thoroughly clean vertical down tube/oil tank below the swingarm to provide a clean clamping surface for the oil filter mount body.
- 2- Place a drain pan under the bike, disconnect the oil return line from the engine and let it drain. See FIG. 1.
- 3- Next remove the return line from the oil tank. See FIG. 2. Save the hose clamps to use on the new hoses.

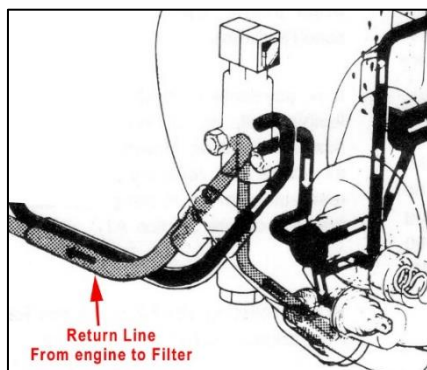

FIG. 1

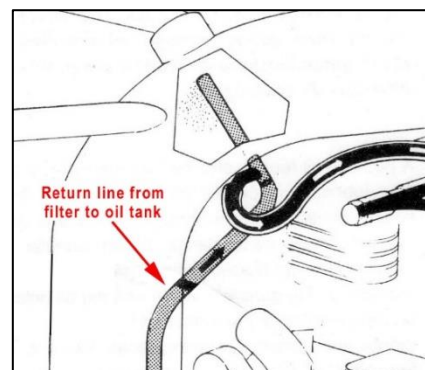

FIG. 2

- 4- Install the threaded filter attaching tube (short side in, notched side out), hose fittings and plugs. Use a small amount of red or blue Loctite (or equivalent) on the threads. **DO NOT** over tighten the hose fittings and plugs. They are tapered pipe thread and overtightening may crack the aluminum body. See FIG. 3

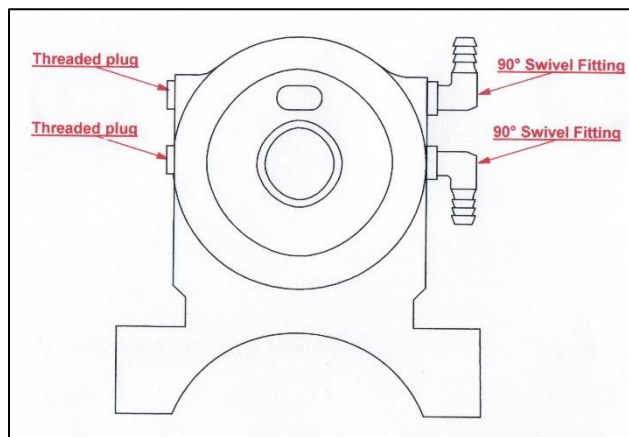

FIG. 3

- 5- The swing arm must be in the full down position, meaning the shocks are fully extended, to ensure there will be no interference between the swing arm and the filter housing. Use the U-bolt to clamp the filter housing to the frame/oil tank tube just below the swing arm, tightening nuts evenly on both sides. A ½" thin wall, 12 point box end wrench works best.

!!DO NOT OVER TIGHTEN THE U-BOLT IT MAY DAMAGE THE FRAME TUBE OR FILTER HOUSING!!

- 6- Ensure the assembly is not touching or interfering with any surrounding components.
- 7- Measure and install supplied hoses. The flow direction in and out of the filter is critical. See Fig. 4.

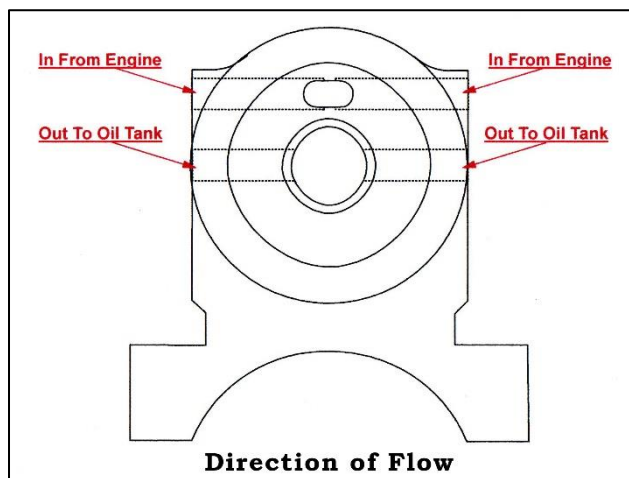

FIG. 4

- 8- Fill the oil filter with oil. This will need to be done a few times, waiting for the oil to soak in and displace the air. When there are no more bubbles, install the filter.
NOTE: If the filter is not filled with oil before installation the rocker arms and shafts may be damaged due to a lack of oil while the filter is being filled by the oil pump.
- 9- Start the engine, let it run for a few minutes, check for leaks and ensure oil is returning to the tank properly.